

# MODEL 264

## 3-Phase Monitor

- Detects Phase Loss, Low Voltage, Phase Reversal
- Adjustable Trip Delay
- Isolated Contacts
- 5 Year Unconditional Warranty

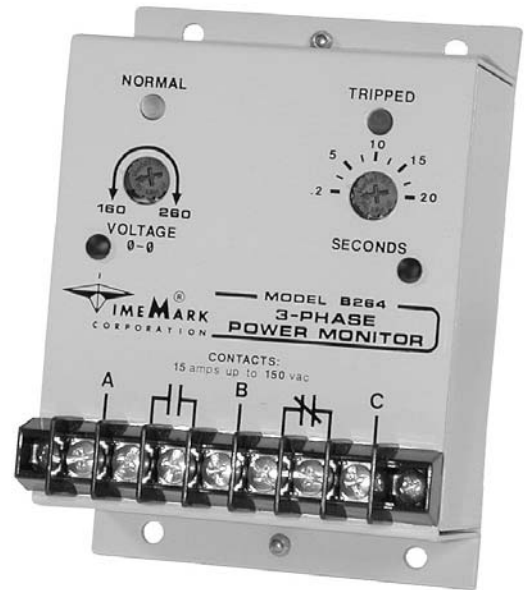

### DESCRIPTION

The Model 264 3-Phase Monitor continuously monitors 3-phase Wye or Delta systems for abnormal conditions. The solid-state electronic sensing circuit drives two separate SPST relays, one normally open and the other normally closed. An adjustable trip delay reduces or eliminates nuisance tripping caused by momentary voltage fluctuations on motor start-up.

Standard versions are 120V, 208/240V, 480V and 575V at 60 Hz; and 380V or 415V at 50 Hz. Voltage ranges are sufficiently wide to allow for proper adjustment to existing conditions. Both TRIPPED and NORMAL indicators are provided to aid in trip point adjustments and system troubleshooting.

The Model 264 is not sensitive to line current and can be used with any size motor or compressor.

### SPECIFICATIONS

Model	A264	B264	C264	D264	EX264-380	EX264-415
Nominal AC Voltage (phase to phase)	120 VAC	208/240 VAC	480VAC	575VAC	380VAC	415VAC
Adjustment Range	85-125V	160-260V	380-500V	450-600V	300-400V	340-460V
Frequency	60 Hz	60 Hz	60 Hz	60 Hz	50 Hz	50 Hz
Power Consumption (per phase)	0.25W	0.5W	1.5W	2.5W	1.5W	1.5W
Transient Protection	2500VAC for 10msec					
Repeat Accuracy	± 0.1% of set point (fixed conditions)					
Response Time	2 +/- 2 to 20 +10/-2 seconds					
Reset Time	0.15 seconds					
Reset Type	Automatic					
Dead Band	Approximately 8% of 125 VAC or 10 VAC					
Output Contacts	One (1) SPST N.O.			One (1) SPST N.C.		
Contact Rating	10 amps at 240VAC resistive					
Expected Relay Life	Mech: 10 million operations Elec: 100,000 operations at rated load					
Operating Temp	- 40° to +130° F					
Humidity Tolerance	0 - 97% w/o condensation					
Enclosure Material	20 gauge steel					
Mounting	Surface					
Weight	10 oz.					

### DIMENSIONS

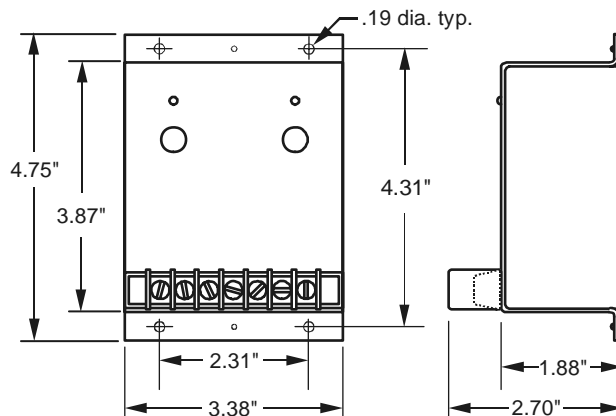

Telephone: Main - (918) 438-1220  
Sales - (800) 862-2875  
Fax: (918) 437-7584

E-mail: sales@time-mark.com  
Internet: http://www.time-mark.com



11440 East Pine Street  
Tulsa, Oklahoma 74116

Doc No. 87A127 05/08  
© 2008 TIME MARK CORPORATION

TIME MARK is a division of  AEMT, Inc.

# MODEL 264 3-Phase Monitor

READ ALL INSTRUCTIONS BEFORE INSTALLING, OPERATING OR SERVICING THIS DEVICE.  
KEEP THIS DATA SHEET FOR FUTURE REFERENCE.

## GENERAL SAFETY

POTENTIALLY HAZARDOUS VOLTAGES ARE PRESENT AT THE TERMINALS OF THE MODEL 264.  
ALL ELECTRICAL POWER SHOULD BE REMOVED WHEN CONNECTING OR DISCONNECTING WIRING.  
THIS DEVICE SHOULD BE INSTALLED AND SERVICED BY QUALIFIED PERSONNEL.

## Installation Instructions

### WARNING

The Model 264 is not to be used in applications where voltages to be monitored or switched will exceed voltage specifications for the particular unit. See 'Adjustment Range' in the Specifications table on the reverse side of this data sheet.

### INSTALLATION

Connect the 3-phase wires to the terminals marked **A**, **B** and **C**. Turn both controls fully counter-clockwise.

Connect the control wires to the terminals with the relay contact markings. **NOTE:** The contact markings on the unit are the TRIPPED condition of the contacts.

Apply power. If the contacts do not transfer when power is applied (NORMAL indicator on), check that all three phases are present, and of the correct voltage. If all phases are correct, rotate the VOLTAGE adjustment counter-clockwise, to the low position. If the contacts still do not transfer, remove power from the unit. Reverse any two of the three input wires, and re-apply power. The contacts should transfer to the normal condition (normally-open contact closed, NORMAL indicator ON).

### ADJUSTMENT

**NOTE:** During adjustment, you may want to install a jumper across the control contacts, to prevent cycling the load on and off.

Set the trip delay to .2 seconds.

Rotate the VOLTAGE adjustment slowly clockwise until the contacts transfer to the failed condition (TRIPPED indicator lit).

Slowly turn the VOLTAGE adjustment counter-clockwise, until the contacts reset to the normal condition (NORMAL indicator on).

If you installed a jumper across the control contacts to prevent load cycling, remove it now.

Set the SECONDS adjustment to the desired amount of trip delay. This trip delay will prevent most nuisance tripping; however, if nuisance tripping does occur, turn the VOLTAGE adjustment slightly farther, counter-clockwise.

In making adjustments to eliminate nuisance tripping, the VOLTAGE adjustment should be rotated in very small increments, until the true nuisance trips are eliminated.

### TYPICAL APPLICATION

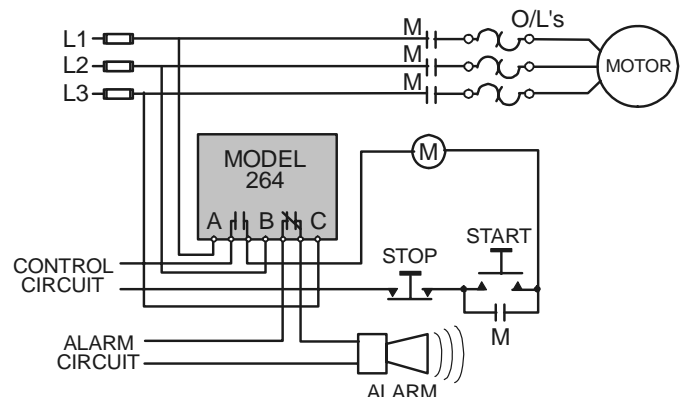

Shown De-Energized

### WARRANTY

The **Model 264 3-Phase Monitor** is covered by Time Mark Corporation's exclusive **5-Year Unconditional Warranty**. Should this device fail, for any reason, within five years from the date of purchase, we will repair or replace it free. Contact the Time Mark Sales department, Monday through Friday; 8 a.m. to 5 p.m., CST, for further details.

Telephone: Main - (918) 438-1220  
Sales - (800) 862-2875  
Fax: (918) 437-7584

E-mail: sales@time-mark.com  
Internet: http://www.time-mark.com



11440 East Pine Street  
Tulsa, Oklahoma 74116

Doc No. 87A127 05/08  
© 2008 TIME MARK CORPORATION

TIME MARK is a division of  AEMT, Inc.