

MODEL 2532

Reverse Phase Relay

- Senses phase reversal on Wye or Delta
- 190 to 500 VAC range
- Machine tool case
- UL Recognized & CSA Certified



DESCRIPTION

The **Model 2532 Reverse Phase Relay** is designed to continuously monitor phase rotation of 3-phase lines. This device should be used in applications where proper phase rotation is critical, such as fan motors, compressors, grinders, elevators, etc.

The solid-state sensing circuit drives an internal electromechanical relay which energizes when power, *with correct phase rotation*, is applied.

The relay will not energize if the applied phases are reversed. It will de-energize if phase rotation is reversed while the motor is running. An LED indicator will illuminate with correct A B C phase rotation.

DIMENSIONS

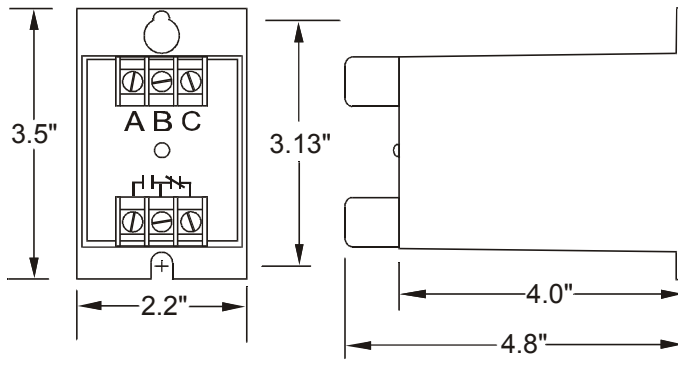

SPECIFICATIONS

Model	2532
Nominal voltage	190-500 VAC (phase to phase)
Frequency	50 to 60 Hz
Power Consumption	2W per phase
Transient protection	2500 VRMS for 10 msec
Repeat accuracy	± 0.1 % (fixed conditions)
Response time	.05 seconds
Reset time	.05 seconds
Reset type	Automatic
Dead band	Approximately 2 %
Output contacts	SPDT 10A at 240 VAC resistive
Expected relay life	Mechanical: 10 million operations Electrical: 100,000 at rated load
Operating temp	- 40° to +131° F
Humidity tolerance	0-97 % w/o condensation
Case material	ABS plastic
Mounting	Surface
Weight	7 oz.
Agency approval	UL Recognized and CSA Certified

Telephone: Main - (918) 438-1220
Sales - (800) 862-2875
Fax: (918) 437-7584

E-mail: sales@time-mark.com
Internet: http://www.time-mark.com



11440 East Pine Street
Tulsa, Oklahoma 74116

Doc No. 87A149 12/00
© 2000 TIME MARK CORPORATION

TIME MARK is a division of  AEMT, Inc.

MODEL 2532 Reverse Phase Relay

READ ALL INSTRUCTIONS BEFORE INSTALLING, OPERATING OR SERVICING THIS DEVICE.
KEEP THIS DATA SHEET FOR FUTURE REFERENCE.

GENERAL SAFETY

POTENTIALLY HAZARDOUS VOLTAGES ARE PRESENT AT THE TERMINALS OF THE MODEL 2532.
ALL ELECTRICAL POWER SHOULD BE REMOVED WHEN CONNECTING OR DISCONNECTING WIRING.
THIS DEVICE SHOULD BE INSTALLED AND SERVICED BY QUALIFIED PERSONNEL.

Installation Instructions

INSTALLATION

Mount the Model 2532 in the desired location.

Connect the 3-phase power to the terminals marked **A**, **B**, and **C**.

Connect the control circuit to the terminals with the contact markings. Refer to the Typical Application wiring diagram for additional information.

If the relay contacts do not transfer when power is applied (LED indicator-Off), check that all three voltages are correct.

If power is present and the voltage is correct, remove power. Reverse two of the three phase connections. Re-apply power.

The contacts should transfer to the normal condition (normally open contacts closed; LED indicator-On). Calibrations or adjustments are not required.

TROUBLESHOOTING

Should the relay fail to operate properly, check that all three voltages are present and are of the correct level. Check all fuses and verify that all wiring connections are correct. Should problems persist, contact the factory for assistance.

TYPICAL APPLICATION

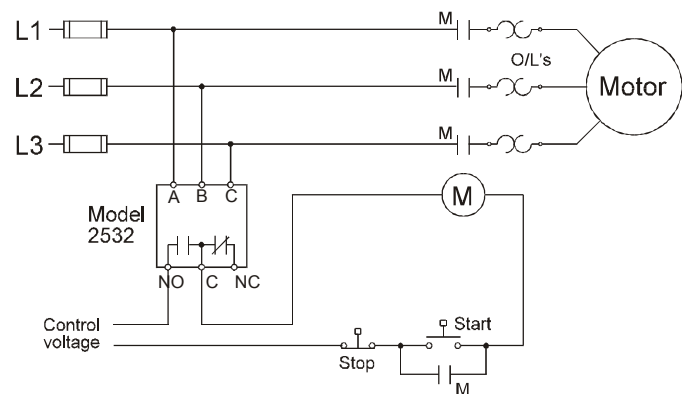

WARRANTY

The **Model 2532 Reverse Phase Relay** is covered by Time Mark Corporation's exclusive **5-Year Unconditional Warranty**. Should this device fail, for any reason, within five years from the date of purchase, we will repair or replace it. Contact the Time Mark Sales department, Monday through Friday; 8 a.m. to 5 p.m., CST, for further details.

Telephone: Main - (918) 438-1220
Sales - (800) 862-2875
Fax: (918) 437-7584

E-mail: sales@time-mark.com
Internet: http://www.time-mark.com



11440 East Pine Street
Tulsa, Oklahoma 74116

Doc No. 87A149 12/00
© 2000 TIME MARK CORPORATION

TIME MARK is a division of  AEMT, Inc.