

# MODEL 252

## 3-Phase Monitor



- Detects Phase Loss, Low Voltage and Phase Reversal
- 50 Hz and 60 Hz versions
- Automatic Reset

### DESCRIPTION

The Model 252 3-Phase Monitor continuously monitors 3-phase power lines for abnormal conditions. When properly adjusted, the Model 252 will detect phase loss on a loaded motor even when regenerated voltage is present.

This device consists of a solid-state voltage and phase-angle sensing circuit, driving an electromechanical relay with one SPDT and one SPST contact. When correct voltage and phase rotation are applied, the internal relay will energize. A fault condition will de-energize the relay. When the fault is corrected the Model 252 will automatically reset.

The Model 252 does not require a neutral connection and can be used with WYE or DELTA configured systems. Four versions cover 120V, 208/240V and 480V, 60Hz, and 380V, 50Hz. Adjustment ranges are sufficiently wide to allow for proper adjustment to existing conditions. Two LED indicators are provided to aid in adjustment and system troubleshooting.



### SPECIFICATIONS

Model	B252B	252B	A252B	EX252B
Nominal AC Voltage	120VAC	208/240VAC	480VAC	380VAC
Adjustment Range	85-120VAC	160-240VAC	380-480VAC	300-380VAC
Frequency	60 Hz			50Hz
Power Consumption	0.25 W	0.50 W	1.5 W	1.25 W
Transient Protection	2500V for 10 msec			
Repeat Accuracy	0.1% of set point (fixed conditions)			
Response Time	0.05 seconds			
Reset Time	0.05 seconds			
Reset Type	Automatic			
Dead Band	2%			
Output Contacts	1 - SPDT		1 - SPST (N.O.)	
Contact Rating	5A at 240VAC resistive			
Expected Relay Life	Mech: 10 million operations Elec: 100,000 at rated load			
Operating Temp	- 40° to 131° F			
Humidity Tolerance	97% w/o condensation			
Enclosure Material	ABS plastic			
Mounting	8-pin socket (*order separately)			
Weight	5 oz.			
Agency Approvals	UL Recognized (U.S. & Canadian)			

\*Order 8-pin socket number 51X120

### TYPICAL APPLICATION

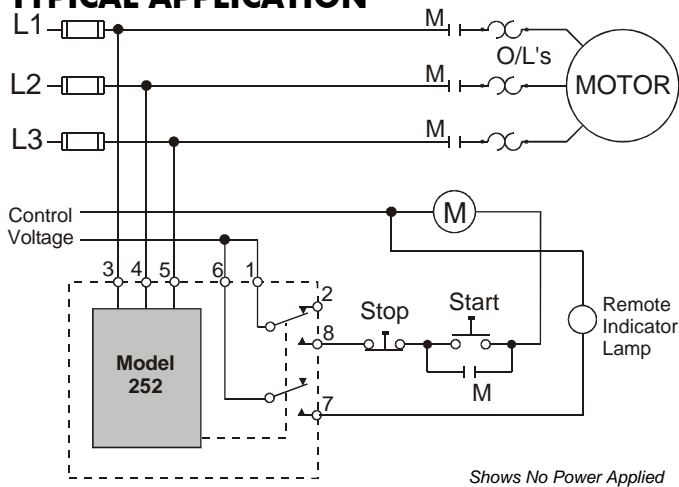

### DIMENSIONS

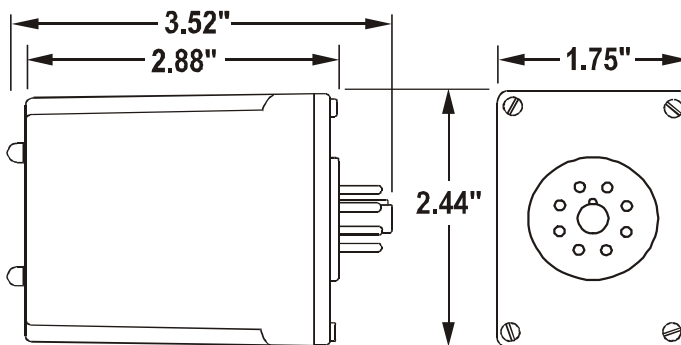

(dimensions have tolerance of  $\pm 0.06$ )

Telephone: Main - (918) 438-1220  
Sales - (800) 862-2875  
Fax: (918) 437-7584

E-mail: sales@time-mark.com  
Internet: http://www.time-mark.com



**TIME MARK**  
CORPORATION

11440 East Pine Street  
Tulsa, Oklahoma 74116

Doc No. 87A373 04/05  
© 2005 TIME MARK CORPORATION

TIME MARK is a division of  AEMT, Inc.

# MODEL 252

# 3-Phase Monitor

READ ALL INSTRUCTIONS BEFORE INSTALLING, OPERATING OR SERVICING THIS DEVICE.  
KEEP THIS DATA SHEET FOR FUTURE REFERENCE.

## GENERAL SAFETY

POTENTIALLY HAZARDOUS VOLTAGES ARE PRESENT AT THE TERMINALS OF THE MODEL 252.  
ALL ELECTRICAL POWER SHOULD BE REMOVED WHEN CONNECTING OR DISCONNECTING WIRING.  
THIS DEVICE SHOULD BE INSTALLED AND SERVICED BY QUALIFIED PERSONNEL.

## Installation Instructions

### INSTALLATION

Mount the socket in a suitable enclosure. A NEMA approved enclosure, designed for socket-mounted relays, is available from Time Mark Corporation.

Connect the 3-phase power to terminals 3, 4 and 5 on the socket. Phase rotation may be verified using a Time Mark Model 108A or 108B Phase Sequence Detector.

Connect the load control wiring to the appropriate terminals on the socket. The SPST contacts (pins 6 and 7) are electrically isolated from the SPDT contacts.

**For motor control and phase loss alarm applications;** use the SPDT contacts.

**For auxiliary indicator applications;** use the appropriate SPST contacts.

Insert the Model 252 into the socket.

Apply power. If the contacts do not transfer, (TRIP indicator-On ), check that all phases are present and of the correct voltage. If power is correct, rotate the level adjustment counter-clockwise.

If the contact still does not transfer, remove power and reverse two of the three phase wires at the socket (phase rotation is reversed). Re-apply power. The contact should transfer to provide a signal path between both sets of normally-open contacts. The green LED (NORMAL) should be lit.

**Note:** When installing the Model 252 in areas of high humidity or contamination, it is recommended that the base area and all exposed metal parts of the socket be coated liberally with a good quality silicon grease, such as Dow Corning DC-4 or DC-4X. Insert the unit into the socket and wipe off excess grease around the base. This will prevent the entrance of moisture and other contaminants into the base and socket area.

### PIN DIAGRAM

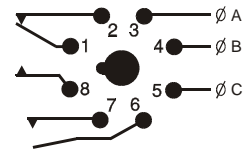

### ADJUSTMENT

The following procedure will adjust the Model 252 to trip below the nominal voltage.

Rotate the level adjustment clockwise, until the relay contact transfers (TRIP indicator On). Slowly turn the adjustment counter-clockwise, until the contact resets. This setting will be correct for most applications.

Should nuisance tripping occur, turn the adjustment slightly farther counter-clockwise, lowering the trip level. A more accurate adjustment procedure requires a 3-phase variac, allowing the voltage to be lowered to a specific voltage. The Model 252 can then be set to trip at this precise voltage level, when installed in the motor control circuit. Factory set versions are also available.

### TROUBLESHOOTING

Should the Model 252 fail to operate properly, check that all three voltages are present and are of the correct level and phase rotation (a Model 108A or 108B Phase Sequence Detector may be used to verify phase rotation). Check all fuses and verify that all wiring connections are correct. Should problems persist, contact the manufacturer at **800-862-2875**.

### WARRANTY

The **Model 252 3-Phase Monitor** is covered by Time Mark Corporation's exclusive **5-Year Unconditional Warranty**. Should this device fail, for any reason, within five years from the date of purchase, we will repair or replace it, free. Contact the Time Mark Sales department for further information.

Telephone: Main - (918) 438-1220

Sales - (800) 862-2875

Fax: (918) 437-7584

E-mail: sales@time-mark.com

Internet: http://www.time-mark.com



**TIME MARK**  
CORPORATION

11440 East Pine Street  
Tulsa, Oklahoma 74116

Doc No. 87A373 04/05  
© 2005 TIME MARK CORPORATION

TIME MARK is a division of  **AEMT, Inc.**