

MODEL 246

3-Phase Monitor



- Monitors for Phase Loss or Reversal, Low and Over Voltage
- Automatic Reset
- CSA Certified
- 5 Year Unconditional Warranty



DESCRIPTION

The **Model 246 3-Phase Monitor** is designed to continuously monitor 3-phase power lines for phase loss, phase reversal, low voltage and high voltage. This device features solid-state voltage and phase angle sensing circuits, which drive a SPDT electromechanical relay. A neutral is not required, allowing the Model 246 to be used with either Wye or Delta systems.

Three versions of the Model 246 cover the 120 and 208/240VAC, 60 Hz and the 380VAC, 50 Hz. In addition, the models **A246** and **B246** are now **CSA Certified**.

Each option on the Model 246 monitor is adjustable throughout its operating range. The adjustment pots and LED indicators for OVER VOLTAGE and UNDER VOLTAGE are mounted on the front of the unit for easy access.

SPECIFICATIONS

Model	A246	B246	EX246
Nominal AC Voltage	120	208/240	380
Adjustment Range			
Low:	85-125 V	160-260 V	300-400 V
High:	110-140 V	210-280 V	350-450 V
Frequency	60 Hz	60 Hz	50 Hz
Power Consumption (per phase)	1 W	1.5 W	2 W
Transient Protection	2500V for 10 msec		
Repeat Accuracy	±0.1% of set point (fixed conditions)		
Response/Reset Time	50 msec		
Reset type	Automatic		
Dead Band	2%		
Contact Rating	SPDT 10A at 240VAC resistive		
Expected Relay Life	Mech: 10 million operations Elec: 100,000 at rated load		
Operating Temperature	- 40° to +131° F		
Humidity Tolerance	0-97% w/o condensation		
Enclosure Material	ABS plastic		
Weight	6 oz.		
Mounting	8-pin socket *order separately		
Agency approval	CSA	CSA	

* Order 8-pin socket number 51X120

TYPICAL APPLICATION

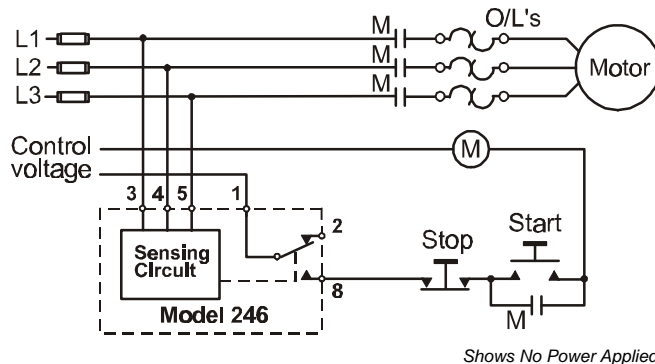

DIMENSIONS

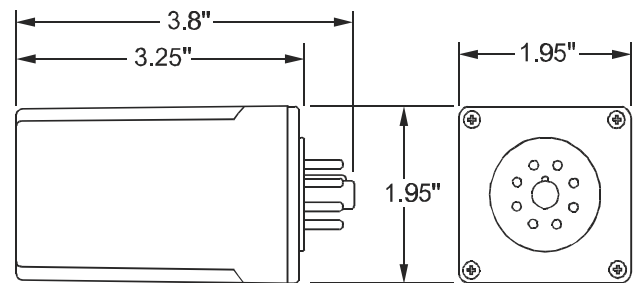

Telephone: Main - (918) 438-1220
Sales - (800) 862-2875
Fax: (918) 437-7584
E-mail: sales@time-mark.com
Internet: http://www.time-mark.com



TIME MARK
CORPORATION

11440 East Pine Street
Tulsa, Oklahoma 74116

Doc No. 87A112 12/00
© 2000 TIME MARK CORPORATION

TIME MARK is a division of AEMT, Inc.

MODEL 246 3-Phase Monitor

READ ALL INSTRUCTIONS BEFORE INSTALLING, OPERATING OR SERVICING THIS DEVICE.
KEEP THIS DATA SHEET FOR FUTURE REFERENCE.

GENERAL SAFETY

POTENTIALLY HAZARDOUS VOLTAGES ARE PRESENT AT THE TERMINALS OF THE MODEL 246.
ALL ELECTRICAL POWER SHOULD BE REMOVED WHEN CONNECTING OR DISCONNECTING WIRING.
THIS DEVICE SHOULD BE INSTALLED AND SERVICED BY QUALIFIED PERSONNEL.

Installation Instructions

WARNING

The Model 246 is not to be used with input voltages greater than those for which the unit was designed.

140VAC for Model A246
280VAC for Model B246

INSTALLATION

Connect the input power to the 8-pin socket, following the Model 246 pin diagram, pictured on the unit, and on this data sheet. Insert the Model 246 into the socket and apply power.

If the contacts do not transfer (*both LEDs-off*), check that all three phases are present and of the correct voltage. If power is correct, rotate the UNDER VOLTAGE adjustment counter-clockwise, and the OVER VOLTAGE adjustment clockwise, to widen the operating band.

If the contacts still do not transfer, remove power and reverse two of the three phase wires, at the socket (*phase rotation is reversed*). Re-apply the power. The contacts should transfer to provide a signal path between pins 1 & 8 (*both LEDs-off*).

NOTE: When installing the **Model 246 Monitor** in areas of high humidity or contamination, it is recommended that the base area and all exposed metal parts of the socket be coated liberally with a good quality silicon grease, such as Dow Corning DC-4 or DC-4X. Insert the unit into the socket and wipe off excess grease around the base. This will prevent the entrance of moisture and other contaminants into the base and socket areas.

ADJUSTMENT PROCEDURE

Set UNDER VOLTAGE level: Rotate the UNDER VOLTAGE adjustment pot clockwise, until the contacts transfer (*UNDER VOLTAGE LED-On*). Slowly turn the UNDER VOLTAGE adjustment counter-clockwise until the contacts reset (*UNDER VOLTAGE LED-Off*).

Set OVER VOLTAGE level: Turn the OVER VOLTAGE adjustment pot counter-clockwise, until the contacts transfer (*OVER VOLTAGE LED-On*). Slowly turn the OVER VOLTAGE adjustment pot clockwise until the contacts reset (*OVER VOLTAGE LED-Off*).

Nuisance tripping: The settings achieved by these adjustments (above), will be correct for most applications. Should nuisance tripping occur, turn the OVER VOLTAGE and the UNDER VOLTAGE adjustments slightly further, widening the operating band.

PIN DIAGRAM

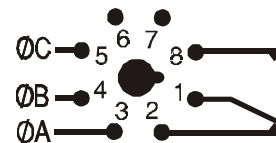

TROUBLESHOOTING

Should the Model 246 3-Phase Monitor fail to operate, check all connections. Verify that all three voltages are present, and check all fuses. Should problems persist, contact the factory for assistance.

WARRANTY

The **Model 246 3-Phase Monitor** is covered by Time Mark Corporation's exclusive **5-Year Unconditional Warranty**. Should this device fail, for any reason, within five years from the date of purchase, we will repair or replace it free. Contact the Time Mark Sales department, Monday through Friday; 8 a.m. to 5 p.m., CST, for further details.

Telephone: Main - (918) 438-1220
Sales - (800) 862-2875

Fax: (918) 437-7584

E-mail: sales@time-mark.com
Internet: http://www.time-mark.com



11440 East Pine Street
Tulsa, Oklahoma 74116

Doc No. 87A112 12/00
© 2000 TIME MARK CORPORATION

TIME MARK is a division of  AEMT, Inc.