

MODEL 2002Y

3-Phase Voltage Unbalance Monitor

- Detects Unbalanced Voltages On Wye Connections
- Percent of Unbalance Adjustment
- Automatic Reset
- Can Energize Relay w/ only 1 Phase and Neutral Connection

DESCRIPTION

The Model 2002Y 3-Phase Voltage Unbalance Monitor is designed to continuously monitor a three-phase line with a neutral connection for unbalanced voltage conditions.

This device will only energize the relay if an unbalance exists. Zero volts on all three phases is considered a balanced condition. This allows the Model 2002Y to be used with shunt breakers, so that main power can be restored without resetting breakers.

The solid-state sensing circuit drives an internal electromechanical relay. Indicator lights on the monitor show when the voltage balance is within an acceptable range; when an unbalance exists; and when the relay is actually tripped.

DIMENSIONS

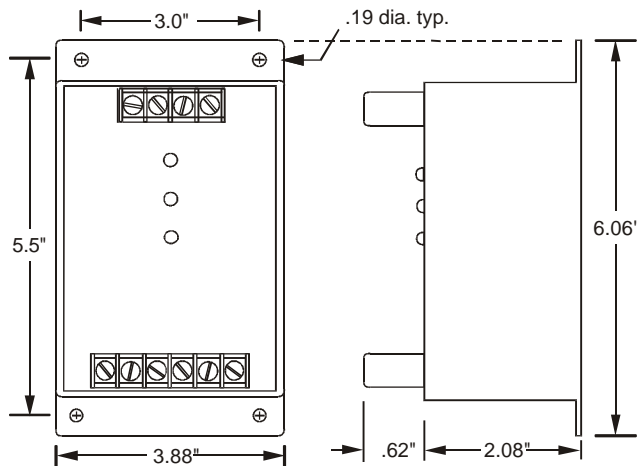

SPECIFICATIONS

Model 2002Y-XXX/YYY	2002Y-69/120	2002Y-120/208	2002Y-138/240	2002Y-220/380	2002Y-240/415	2002Y-277/480
Phase-Neutral Voltage	69 VAC	120 VAC	138 VAC	220 VAC	240 VAC	277 VAC
Phase-Phase Voltage	120 VAC	208VAC	240VAC	380VAC	415VAC	480VAC
Voltage Range	± 15%	± 15%	± 15%	± 15%	± 15%	± 15%
Frequency	50Hz - 60Hz					
Power Consumption (per phase max)	2.0W	2.0W	2.0W	2.0W	2.0W	2.0W
Transient Protection	2500VRMS for 10msec					
Repeat Accuracy	± 0.1% (fixed conditions)					
Unbalance Adjustment	2% to 10%					
Response Time	150 msec					
Reset Time	Fixed 1 sec					
Dropout Time	Adjustable 0.2 to 20 seconds					
Reset Type	Automatic					
Dead Band	0.5% max					
Contact Rating	DPDT 10 amps at 240VAC resistive					
Expected Relay Life	Mech: 10 million operations Elec: 100,000 operations at rated load					
Operating Temp	- 40° to +131° F					
Humidity Tolerance	0-97% w/o condensation					
Mounting	Surface					
Enclosure Material	ABS plastic					
Weight	10 oz.					

Telephone: Main - (918) 438-1220
Sales - (800) 862-2875
Fax: (918) 437-7584

E-mail: sales@time-mark.com
Internet: http://www.time-mark.com



11440 East Pine Street
Tulsa, Oklahoma 74116

Doc No. 87A320 06/05
© 2005 TIME MARK CORPORATION

TIME MARK is a division of  AEMT, Inc.

MODEL 2002Y 3-Phase Voltage Unbalance Monitor

READ ALL INSTRUCTIONS BEFORE INSTALLING, OPERATING OR SERVICING THIS DEVICE.
KEEP THIS DATA SHEET FOR FUTURE REFERENCE.

GENERAL SAFETY

POTENTIALLY HAZARDOUS VOLTAGES ARE PRESENT AT THE TERMINALS OF THE MODEL 2002Y.
ALL ELECTRICAL POWER SHOULD BE REMOVED WHEN CONNECTING OR DISCONNECTING WIRING.
THIS DEVICE SHOULD BE INSTALLED AND SERVICED BY QUALIFIED PERSONNEL.

Installation Instructions

INSTALLATION

Set PERCENT OF UNBALANCE fully clockwise.

Set TRIP DELAY IN SECONDS fully counter-clockwise.

Connect the 3-phase wires to the terminals marked 'A', 'B' and 'C' and neutral connection to 'N'.

Connect the control wires to the terminals with the relay contact markings. The contact markings on the unit are the NORMAL or OFF condition of the contacts.

Apply power. NORMAL indicator should be ON.

ADJUSTMENT

Rotate the PERCENT OF UNBALANCE adjustment pot to the desired setting. The percentage of unbalance is calculated as follows using phase to neutral voltages:

$$\% \text{ Unbalance} = \frac{V_{\max} - V_{\min}}{V_{\max}}$$

Set the TRIP DELAY adjustment to the desired amount of delay to prevent nuisance trips.

Should nuisance trips occur, increase the TRIP DELAY IN SECONDS setting. Any adjustments should be made in very small increments.

WARRANTY

The **Model 2002Y 3-Phase Voltage Unbalance Monitor** is covered by Time Mark Corporation's exclusive **5-Year Unconditional Warranty**. Should this device fail, for any reason, within five years from the date of purchase, we will repair or replace it free. Contact the Time Mark Sales department, Monday through Friday; 8 a.m. to 5 p.m., CST, for further details.

TYPICAL MOTOR APPLICATION

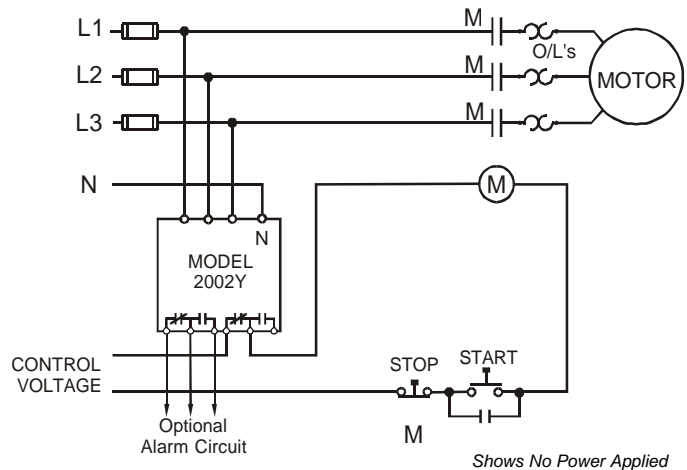

TYPICAL SHUNT BREAKER APPLICATION

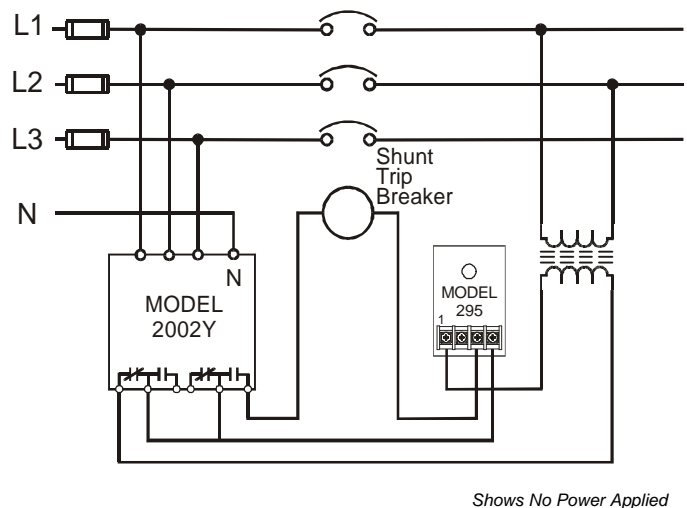

Telephone: Main - (918) 438-1220
Sales - (800) 862-2875
Fax: (918) 437-7584

E-mail: sales@time-mark.com
Internet: http://www.time-mark.com



11440 East Pine Street
Tulsa, Oklahoma 74116
Doc No. 87A320 06/05
© 2005 TIME MARK CORPORATION

TIME MARK is a division of  AEMT, Inc.