

MODEL 158 MODEL 158R

3-Phase Monitor

- Surface-mount for HVAC Applications
- Optional 5 Minute Short Cycle Time Delay
- Detect Phase Loss, Low Voltage, Phase Reversal
- 5 Year Unconditional Warranty



DESCRIPTION

The **Model 158** continuously monitors 3-phase power lines for abnormal conditions. When properly adjusted, the Model 158 monitor will detect phase loss on a loaded motor even when regenerated voltage is present.

This device consists of a solid-state voltage and phase-angle sensing circuit, driving an electro-mechanical relay. When correct voltage and phase rotation are applied, the internal relay will energize. A fault condition will de-energize the relay. When the fault is corrected, the monitor will automatically reset.

The Model 158 does not require a neutral connection, and can be used with Wye or Delta systems. Four versions cover 120V, 208/240V, 480V (60 Hz) and 380V (50 Hz). Voltage ranges are sufficient to allow for proper adjustment to existing conditions. A front-mounted LED failure indicator is provided.

The "R" versions of the Model 158 Monitor have an additional LED indicator for RESTART, and a 5 minute short cycle timer, to delay restarting the motor.

SPECIFICATIONS

MODEL	B158B	158B	A158B	EX158B
Input Voltage	120vac	208/240vac	480vac	380vac
Adjustment Range	85-125vac	160-260vac	380-500vac	300-400vac
Frequency	60 Hz	60 Hz	60 Hz	50 Hz
Power Consumption (per phase)	.25 W	.5 W	1.5 W	1.25 W
Transient Protection	2500 VRMS of 10 msecs			
Repeat Accuracy	± 0.1% of setpoint (fixed conditions)			
Response Time	0.5 seconds			
Reset Time	Short cycle restart delay - 2 seconds "R" versions - 5 minutes			
Reset Type	Automatic			
Dead Band	2%			
Output contacts	SPDT 10A at 240vac resistive			
Expected Relay Life	Mech: 10 million operations Elec: 100,000 operations at rated load			
Operating Temp	-40° to +131° F			
Humidity Tolerance	97% w/o condensation			
Enclosure Material	ABS plastic			
Mounting	Surface			
Weight	5 oz.			

ADDITIONAL ORDERING INFO:

add an "R" to any 158 model number above, for the 5 minute time delay option

DIMENSIONS

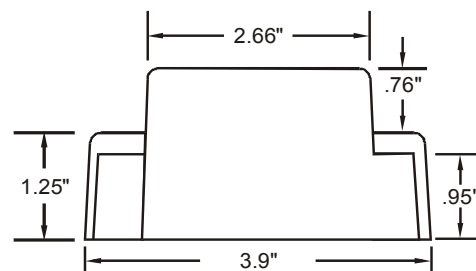
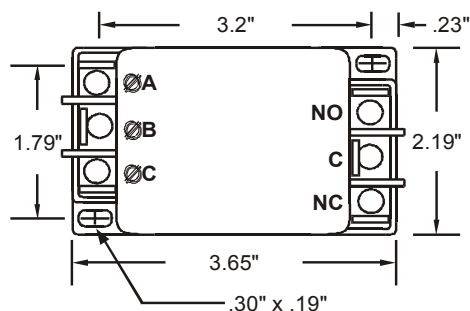

Telephone: Main - (918) 438-1220
Sales - (800) 862-2875
Fax: (918) 437-7584

E-mail: sales@time-mark.com
Internet: http://www.time-mark.com



11440 East Pine Street
Tulsa, Oklahoma 74116

Doc No. 87A254 03/02
© 2002 TIME MARK CORPORATION

TIME MARK is a division of  AEMT, Inc.

MODEL 158 (R) 3-Phase Monitor

READ ALL INSTRUCTIONS BEFORE INSTALLING, OPERATING OR SERVICING THIS DEVICE.
KEEP THIS DATA SHEET FOR FUTURE REFERENCE.

GENERAL SAFETY

POTENTIALLY HAZARDOUS VOLTAGES ARE PRESENT AT THE TERMINALS OF THE MODEL 158.
ALL ELECTRICAL POWER SHOULD BE REMOVED WHEN CONNECTING OR DISCONNECTING WIRING.
THIS DEVICE SHOULD BE INSTALLED AND SERVICED BY QUALIFIED PERSONNEL.

Installation Instructions

INSTALLATION

Mount the Model 158 3-Phase Monitor in a suitable enclosure.

Attach 1/4" terminal lugs to the input voltage wires, and then connect them to the terminals on the Model 158 marked $\emptyset A$, $\emptyset B$, and $\emptyset C$. Proper **clockwise** phase rotation should be confirmed, using a Time Mark Model 108A or 108B Phase Rotation Indicator or unit will show trip for Phase Reversal.

Attach 1/4" terminal lugs to the load control circuit wires, then connect them to the terminals marked **C** and **NO**.

Apply power. The **NO** contact will close when correct voltage is applied. **If a Model 158R is being installed, there will be a 5 minute delay before the contact transfers. The green RESTART light should be ON during this 5 minute period.**

ADJUSTMENT PROCEDURE

NOTE: While adjusting the trip level, you may wish to jumper the control circuit contacts to prevent the device from tripping the load on and off.

Slowly rotate the FAILURE LEVEL ADJUST pot clockwise, until the TRIPPED indicator LED just illuminates, and the contacts transfer.

Rotate the FAILURE LEVEL ADJUST pot counter-clockwise, until the TRIPPED indicator LED goes out, and the contacts re-energize. **On the "158R" version, the green RESTART light will be ON, and there will be a 5 minute delay period before the contacts re-energize.**

Should nuisance tripping occur, after completing these adjustments, turn the FAILURE LEVEL ADJUST pot slightly further counter-clockwise, as necessary. **Remove the jumper from the control circuit contact, if one was applied.**

TROUBLESHOOTING

There are no user-serviceable parts in the Model 158 3-Phase Monitor. Should the unit fail to operate properly, check that correct voltage and clockwise phase rotation are being applied. Check all fuses and wiring connections. Should problems persist, contact your local Time Mark Distributor, or the factory at 800-862-2875 (Monday-Friday; 8 a.m. to 5 p.m. CST), for further assistance.

APPLICATION DIAGRAMS

Typical compressor application

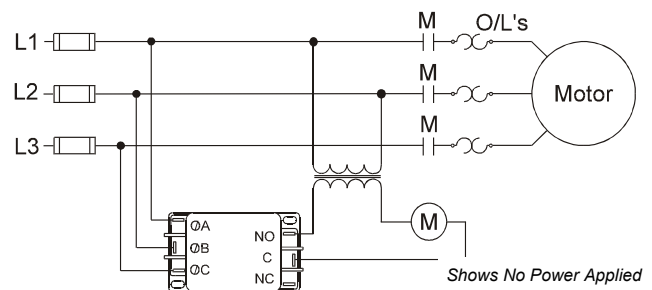

Typical motor control application

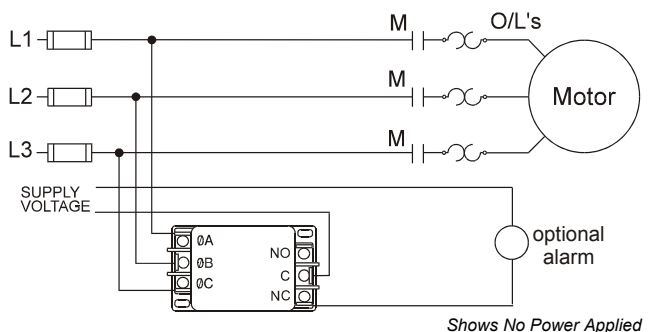

WARRANTY

The **Model 158 3-Phase Monitor** is warranted to be free from defects in materials and workmanship, and is covered by our exclusive **5-year Unconditional Warranty**. If the Model 158 fails to operate, for any reason, we will repair or replace it free, for five years from the date of purchase. Contact the Time Mark Sales department, Monday through Friday; 8 a.m. to 5 p.m., CST, for further details.

Telephone: Main - (918) 438-1220
Sales - (800) 862-2875
Fax: (918) 437-7584

E-mail: sales@time-mark.com
Internet: http://www.time-mark.com



TIME MARK
CORPORATION

11440 East Pine Street
Tulsa, Oklahoma 74116
Doc No. 87A254 03/02
© 2002 TIME MARK CORPORATION

TIME MARK is a division of  AEMT, Inc.